

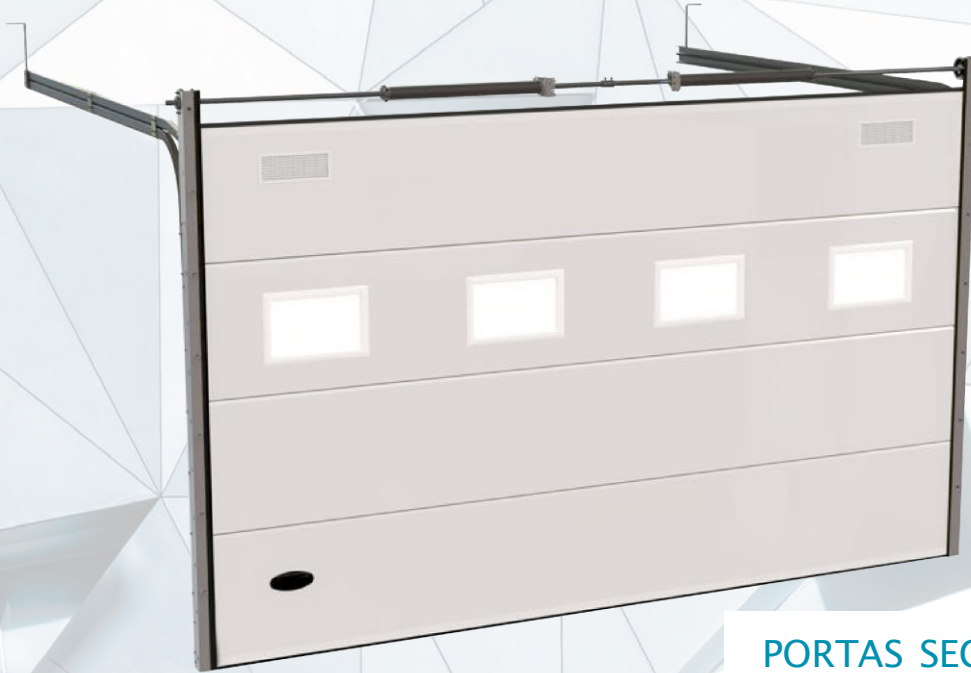

**M&Q Solutions**  
Portas - Portões - Automatismos



## PORTAS SECCIONADAS

ES. PUERTAS SECCIONALES

EN. SECTIONAL DOORS

FR. PORTES SECTIONNELLES

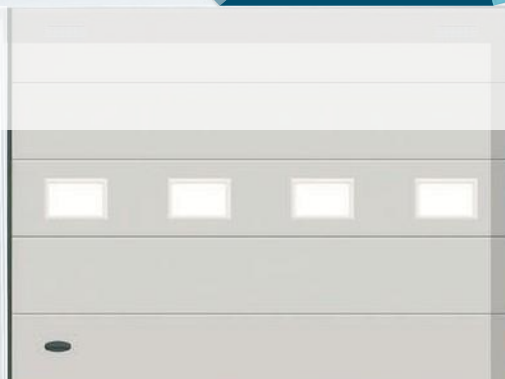

## ESQUEMA GERAL

ES. Esquema General  
EN. Overall Scheme  
FR. Schéma Général

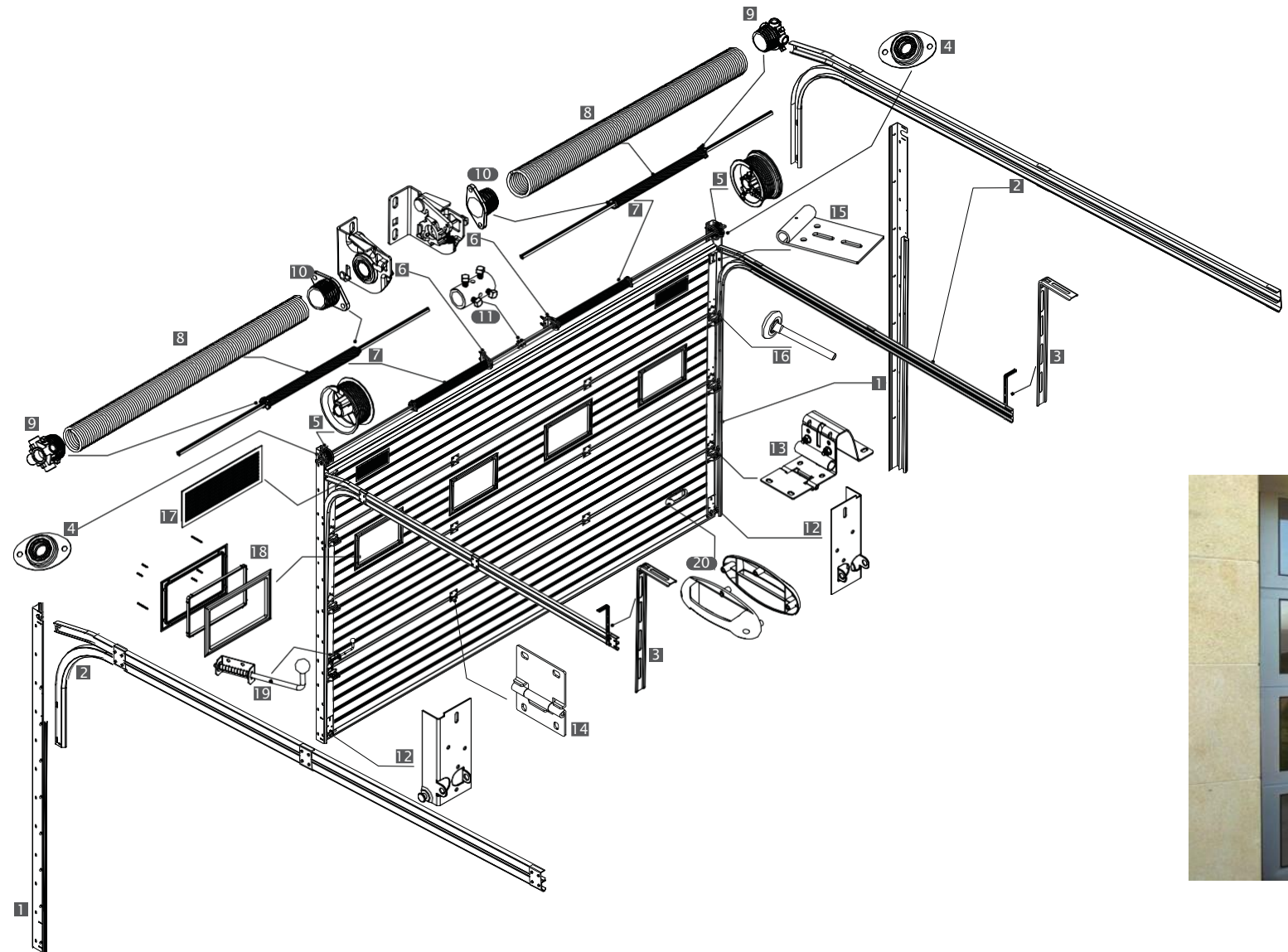

1 CALHAS VERTICAIS  
ES. Guías Verticales  
EN. Vertical track set  
FR. Set de rails verticaux

2 CALHAS HORIZONTAIS  
ES. Guías Horizontales  
EN. Horizontal track set  
FR. Set de rails horizontaux

3 SUPORTE DE TETO  
ES. Escuadra de soporte  
EN. Track Support Bracket  
FR. Support L

4 SUPORTE DE ROLAMENTO  
ES. Soporte de Rolamiento  
EN. Bearing Bracket  
FR. Palier avec roulement

5 TAMBORES  
ES. Poleas  
EN. Lift Drums  
FR. Tambours pour cables

6 RUTURAS DE MOLAS  
ES. Freno de Muelle  
EN. Spring Break Device  
FR. Frein à ressort

7 TUBO COM ESCATEL E MOLAS  
ES. Tubo con chavetero y muelles  
EN. Shaft with Keyway and Springs  
FR. Arbre avec rainure étirée et ressort

8 MOLAS DE TORÇÃO  
ES. Muelles de Torsión  
EN. Torsion Springs  
FR. Ressorts

9 e 10- PEÇAS DE TORÇÃO  
ES. Piezas de Torsión  
EN. Torsion Spring Fittings  
FR. Mandrins

11 EMENDA TUBO  
ES. Acoplamiento de Eje  
EN. Shaft Coupler  
FR. Accouplement pour arbre

12 SUPORTE CABO DE AÇO  
ES. Placa base  
EN. Bottom Bracket  
FR. Support de câble

13 CAVALETE LATERAL  
ES. Caballete Lateral  
EN. Side Hinge  
FR. Charnière latérale

14 DOBRADIÇA CENTRAL  
ES. Bisagra Intermedia  
EN. Intermediate Hinge  
FR. Charnière Intermédiaire

15 PORTA RODAS SUPERIOR  
ES. Portarrodillos Superior  
EN. Top roller bracket  
FR. Support de galet haut

16 RODAS  
ES. Rodillos  
EN. Roller  
FR. Galets

17 GRELHA DE VENTILAÇÃO  
ES. Rejillas de Ventilación  
EN. Ventilation Grille  
FR. Grilles de ventilation

18 VISOR  
ES. Mirilla  
EN. Window  
FR. Hublot

19 TRANQUEIRO  
ES. Tranquero  
EN. Slide Lock  
FR. Fermeture intérieur

20 PUNHO  
ES. Tirador  
EN. Handle  
FR. Poignée



# PORTAS SECCIONADAS

ES. PUERTAS SECCIONALES  
 EN. SECTIONAL DOORS  
 FR. PORTES SECTIONNELLES

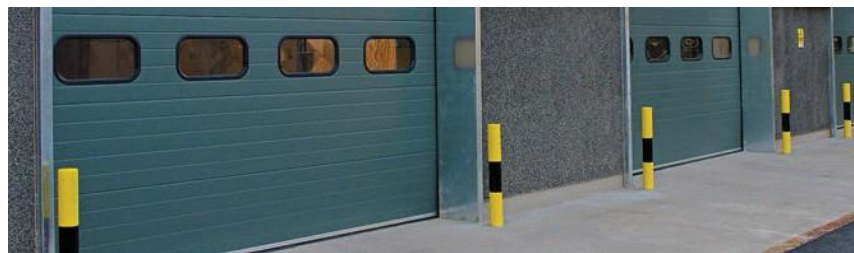
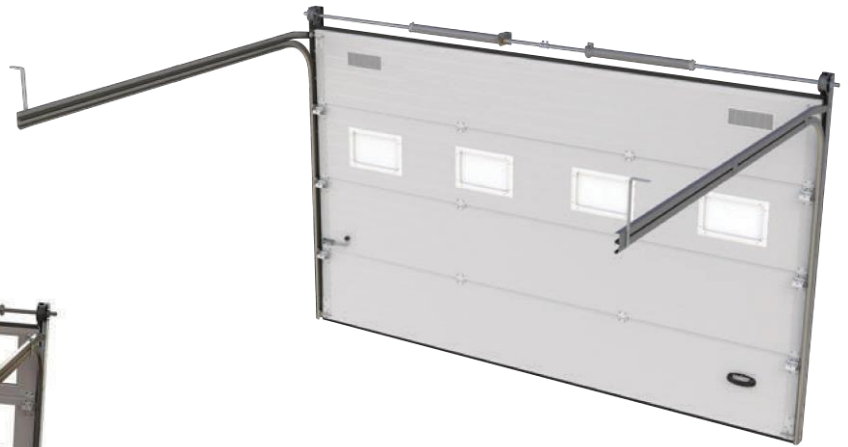

## PORTA DE SERVIÇO INDEPENDENTE

ES. PUERTA PEATONAL INDEPENDIENTE  
 EN. INDEPENDENT DOOR  
 FR. PORTILLON INDÉPENDANT

COM O MESMO DESIGN DA PORTA SECCIONADA  
 ES. Con el mismo diseño de la puerta seccional  
 EN. With the same design as the sectional door  
 FR. Avec la même conception de la porte sectionnelle

OPÇÃO FECHADURA 3 PONTOS  
 ES. Opción Cerradura con 3 Puntos  
 EN. Option 3 Points Lock  
 FR. Option Serrure avec 3 Points

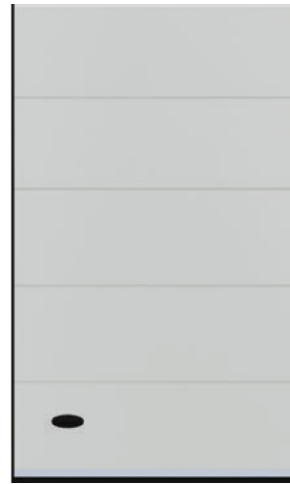

## PORTA DE SERVIÇO

ES. PUERTA PEATONAL  
 EN. WICKET DOOR  
 FR. PORTILLON

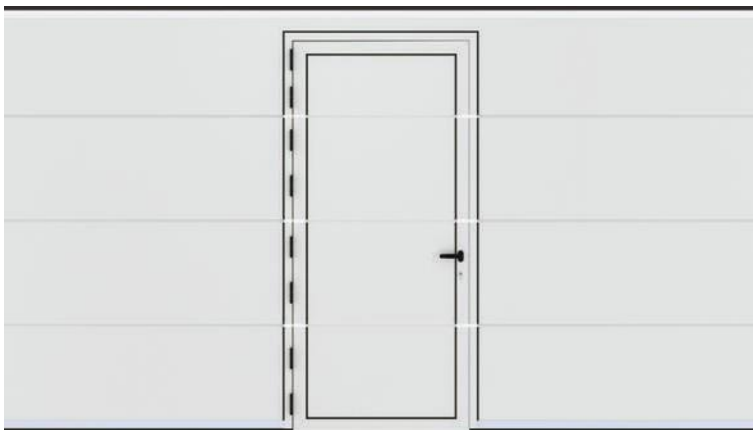

DOBRADIÇA NORMAL  
 ES. Bisagras Normales  
 EN. Normal Hinges  
 FR. Charnières Normales

SOLEIRA ALTA ou SOLEIRA REDUZIDA  
 ES. Umbral Elevado o Reducido  
 EN. High or Low Threshold  
 FR. Seuil Haut ou Plat

OPÇÃO 3 FECHADURAS  
 ES. Opción 3 Cerraduras  
 EN. Option 3 Locks  
 FR. Option 3 Serrures



DOBRADIÇA OCULTA  
 ES. Bisagras Ocultas  
 EN. Hidden Hinges  
 FR. Charnières Masquées

SOLEIRA ALTA ou SOLEIRA REDUZIDA  
 ES. Umbral Elevado o Reducido  
 EN. High or Low Threshold  
 FR. Seuil Haut ou Plat

OPÇÃO 3 FECHADURAS  
 ES. Opción 3 Cerraduras  
 EN. Option 3 Locks  
 FR. Option 3 Serrures



## ROBUSTEZ

ES. ROBUSTEZ | EN. ROBUSTNESS | FR. ROBUSTESSE

## SEGURANÇA

ES. SEGURIDAD | EN. SAFETY | FR. SECURITE

## CONFORTO

ES. CONFORT | EN. COMFORT | FR. CONFORT

## ATENÇÃO AOS DETALHES

ES. ATENCIÓN AL DETALLE  
EN. ATTENTION TO DETAIL  
FR. SOUCI DU DÉTAIL



## SOLUÇÕES À SUA MEDIDA

ES. SOLUCIONES A MEDIDA | EN. CUSTOM SOLUTIONS | FR. SOLUTIONS SURMESURE



**ANTI-ENTALAMENTO**  
ES. CONTRA PINZAMIENTO DE DEDOS  
EN. PINCH-PROOF  
FR. ANTI-PINCEMENT



**COR PERSONALIZADA**  
ES. Color Personalizado  
EN. Custom Colors  
FR. Couleur Personnalisée  
**NÓS PINTAMOS!**  
ES. PINTAMOS!  
EN. WE PAINT!  
FR. NOUS PEIGNONS

### OS NOSSOS PAINÉIS

ES. Nuestros Paneles  
EN. Our Panels  
FR. Nos Panneaux

### ESPECIFICAÇÕES TÉCNICAS | ES. Especificaciones técnicas | EN. Technical Specifications | FR. Caractéristiques techniques

**Força de aderência: ± 0,18 MPa**  
ES. Fuerza de adherencia: ± 0,18 MPa  
EN. Adhesive strength: ± 0.18 MPa  
FR. Force d'adhérence: ± 0,18 MPa

**Resistência à compressão: ± 0,10 MPa**  
ES. Resistencia a la compresión: ± 0,10 MPa  
EN. Compressive strength: ± 0.10 MPa  
FR. Résistance à la compression: ± 0,10 MPa

**Condutividade térmica: ± 0,025 W/mk**  
ES. Conductividad térmica: ± 0,025 W/mk  
EN. Thermal conductivity: ± 0,025 W/mk  
FR. Conductivité thermique: ± 0,025 W/mk

**Peso: 9,28 Kg/m<sup>2</sup>**  
ES. Peso: 9,28 Kg/m<sup>2</sup>  
EN. Weight: 9,28 Kg/m<sup>2</sup>  
FR. Poids: 9,28 Kg/m<sup>2</sup>

**Densidade: ± 40 Kg/m<sup>3</sup> ± 10%**  
ES. Densidad: ± 40 Kg/m<sup>3</sup> ± 10%  
EN. Density: ± 40 Kg/m<sup>3</sup> ± 10%  
FR. Densité: ± 40 Kg/m<sup>3</sup> ± 10%

**Todo o painel está coberto com um filme de proteção**  
ES. Todo el panel está cubierto con una película de protección  
EN. All panels are wrapped in a protective PVC film  
FR. L'ensemble du panneau est recouvert d'un film protecteur adhésif PVC

**Coefficiente de transmissão térmica: Painel 610 mm/500 mm sem junta: U = 0,76 W/m<sup>2</sup>K**  
ES. Coeficiente de transmisión térmica: Panel 600 mm / 500 mm sin junta: U = 0,76 W / m<sup>2</sup>K  
EN. Heat transfer coefficient: -Panel 600 / 500 mm without seal: U= 0.76 W/m<sup>2</sup>K  
FR. Coefficient de transfert de chaleur: Panneau de 600mm / 500mm sans joint U = 0,76 W / m<sup>2</sup>K

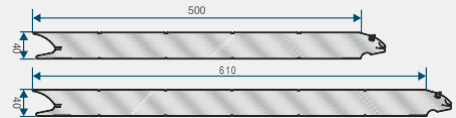

## SUPERLISO

ES. SUPERLISO  
EN. SUPERSMOOTH  
FR. SUPER LISSE



**ACABAMENTO LISO**  
ES. ACABADO LISO  
EN. FINISHING SMOOTH  
FR. FINITION LISSE



**MADEIRA CLARA**  
ES. MADERA CLARA  
EN. LIGHT WOOD  
FR. BOIS CLAIR



**PRETO ONDA**  
ES. NEGRO OLA  
EN. BLACK WAVE  
FR. NOIR ONDE



**MADEIRA ESCURA**  
ES. MADERA OSCURA  
EN. DARK WOOD  
FR. BOIS FONCÉ



**CINZA 7016**  
ES. GRIS 7016  
EN. GRAY 7016  
FR. GRIS 7016



**BRANCO 9010**  
ES. BLANCO 9010  
EN. WHITE 9010  
FR. BLANC 9010



## CANELADO V

ES. ACANALADO V  
EN. RIBBED V  
FR. ONDULÉ V



ACABAMENTO WOODGRAIN  
ES. ACABADO WOODGRAIN  
EN. FINISHING WOODGRAIN  
FR. FINITION WOODGRAIN

\*ACABAMENTO STUCCO  
ES. \*ACABADO STUCCO  
EN. \*FINISHING STUCCO  
FR. \*FINITION STUCCO

OPCIONAL: CHAPA DE ALUMÍNIO\*  
ES. Opcional: PLACA DE ALUMINIO\*  
EN. Optional: ALUMINUM SHEET\*  
FR. En Option: TÔLE D'ALUMINIUM\*

BRANCO 9010  
ES. BLANCO 9010  
EN. WHITE 9010  
FR. BLANC 9010



## CORES DISPONÍVEIS

ES. Cores disponíveis | EN. Available Colors | FR. Couleurs Disponibles

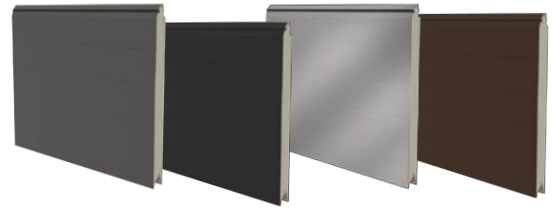

CINZA RAL 7011	CINZA RAL 7016	CINZA METÁLICO RAL 9006	CASTANHO RAL 8014
ES. GRIS 7011	ES. GRIS 7016	ES. GRIS 9006	ES. MARRÓN 8014
EN. GRAY 7011	EN. GRAY 7016	EN. GRAY 9006	EN. BROWN 8014
FR. GRIS 7011	FR. GRIS 7016	FR. GRIS 9006	FR. MARRON 8014



VERDE RAL 6009	VERDE RAL 6005	BEGE RAL 1015	AZUL RAL 5010	VERMELHO RAL 3000
ES. VERDE 6009	ES. VERDE 6005	ES. CREMA 1015	ES. AZUL 5010	ES. ROJO 3000
EN. GREEN 6009	EN. GREEN 6005	EN. BEIGE 1015	EN. BLUE 5010	EN. RED 3000
FR. VERT 6009	FR. VERT 6005	FR. BEIGE 1015	FR. BLEU 5010	FR. ROUGE 3000

## ALMOFADADO

ES. CUARTERON  
EN. CASSETTE  
FR. CASSETTE



ACABAMENTO WOODGRAIN  
ES. ACABADO WOODGRAIN  
EN. FINISHING WOODGRAIN  
FR. FINITION WOODGRAIN

BRANCO 9010  
ES. BLANCO 9010  
EN. WHITE 9010  
FR. BLANC 9010



## CANELADO U

ES. ACANALADO U  
EN. RIBBED U  
FR. ONDULÉ U



MADEIRA CLARA  
ES. MADERA CLARA  
EN. LIGHT WOOD  
FR. BOIS CLAIR



MADEIRA ESCURA  
ES. MADERA OSCURA  
EN. DARK WOOD  
FR. BOIS FONCÉ



OPCIONAL: DUAS FACES  
ES. Opcional: DOS CARAS EN.  
Optional: DOUBLE SIDED FR.  
En Option: DOUBLE FACE

## UNICANAL V

ES. UNICANAL V  
EN. CENTER RIBBED V  
FR. RAINURÉ V



RAL 7016 TEXTURADO  
ES. RAL 7016 TEXTURADO  
EN. RAL 7016 TEXTURED  
FR. RAL 7016 TEXTURE

## UNICANAL U

ES. UNICANAL U  
EN. CENTER RIBBED U  
FR. RAINURÉ U



ACABAMENTO LISO  
ES. ACABADO LISO  
EN. FINISHING SMOOTH  
FR. FINITION LISSE



MADEIRA CLARA  
ES. MADERA CLARA  
EN. LIGHT WOOD  
FR. BOIS CLAIR



MADEIRA ESCURA  
ES. MADERA OSCURA  
EN. DARK WOOD  
FR. BOIS FONCÉ



BRANCO 9010  
ES. BLANCO 9010  
EN. WHITE 9010  
FR. BLANC 9010

# CRIAMOS PRODUTOS PARA SIMPLIFICAR O SEU DIA-A-DIA.

ES. CREAMOS PRODUCTOS PARA  
SIMPLIFICAR SU VIDA DIARIA.  
EN. WE CREATE PRODUCTS TO  
SIMPLIFY YOUR DAILY LIFE.  
FR. NOUS CRÉONS DES PRODUITS POUR  
VOUS SIMPLIFIER LA VIE QUOTIDIENNE.



## DISPOSITIVOS DE SEGURANÇA

ES. Dispositivos de Seguridad  
EN. Safety Devices  
FR. Dispositifs de Sécurité



## VISORES

ES. Mirillas | EN. Windows | FR. Hub



330 x 330mm



310 x 310mm



500 x 530mm

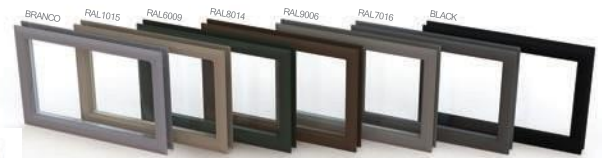

330 x 330mm



665 x 345mm



609 x 203mm



670 x 345mm



PAINEL EM ALÚMINIO ENVIDRAÇADO  
ES. PANEL DE ALUMINIO ACRISTALADO  
EN. ALUMINIUM PANEL GLAZED  
FR. PANNEAU EN ALUMINIUM VITRÉ

## GRELHAS DE VENTILAÇÃO

ES. Rejillas De Ventilación | EN. Ventilation Grilles | FR. Grilles de ventilation



500 X 330mm



337 X 131mm



255 x 135mm



PAINEL EM ALÚMINIO VENTILADO  
ES. PANEL DE ALUMINIO VENTILADO  
EN. ALUMINIUM PANEL VENTILATED  
FR. PANNEAU EN ALUMINIUM VENTILÉ

## PUNHOS E FECHADURAS

ES. Tiradores y Cerraduras | EN. Handles and Locks | FR. Poignées et Serrures





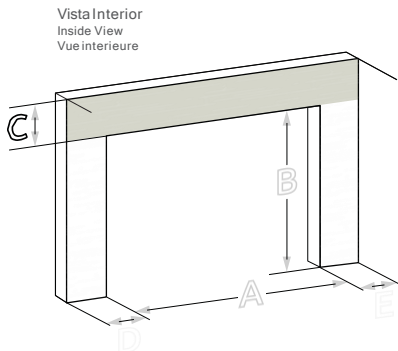
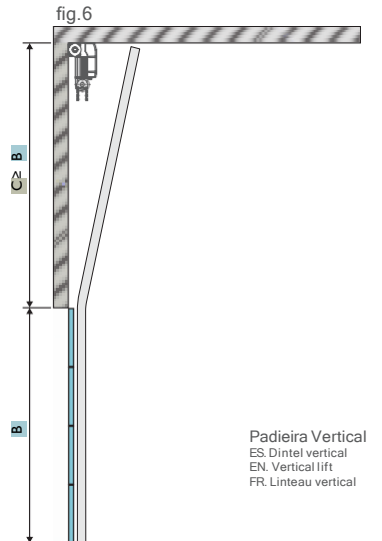
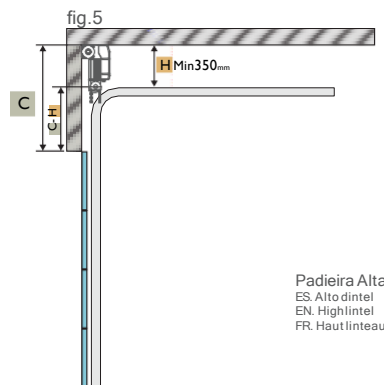
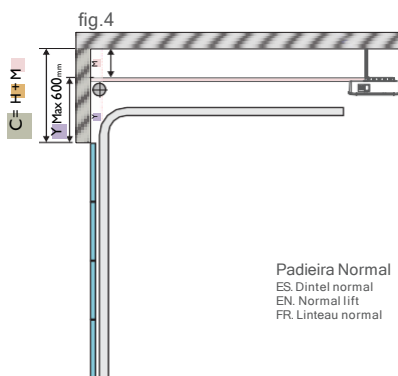
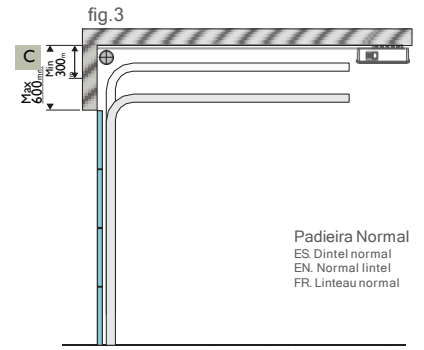
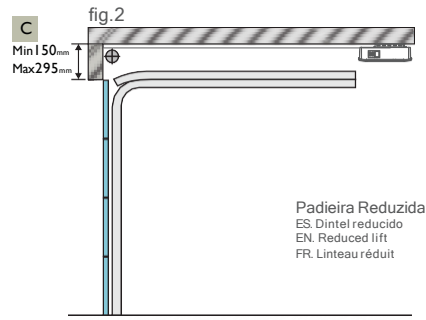
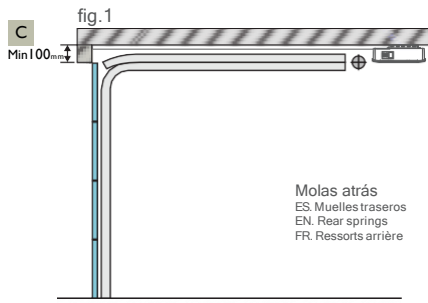

- |                                                                                                                                                    |                                                                                                                                                   |                                                              |
|----------------------------------------------------------------------------------------------------------------------------------------------------|---------------------------------------------------------------------------------------------------------------------------------------------------|--------------------------------------------------------------|
| <b>C</b> Padieira<br>ES. Dintel<br>EN. Lintel<br>FR. Linteau                                                                                       | <b>B</b> Altura da Porta<br>ES. Altura de la puerta<br>EN. Door Height<br>FR. Porte hauteur                                                       | <b>⊕</b> Molas<br>ES. Muelles<br>EN. Springs<br>FR. Ressorts |
| <b>H</b> Distância da calha aoteto<br>ES. Distancia de guías al techo<br>EN. Distance from guides to ceiling<br>FR. Distance des guides au plafond | <b>M</b> Distância do teto ao motor<br>ES. Distancia del techo al motor<br>EN. Distance from ceiling to Motor Rail<br>FR. Distance plafond-moteur |                                                              |

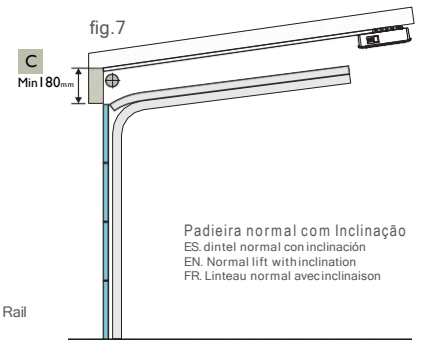



*we open*  
— THE —  
**DOORS**  
*to the*  
**FUTURE**